

# INVICTUS 35 AR

## Data Sheet

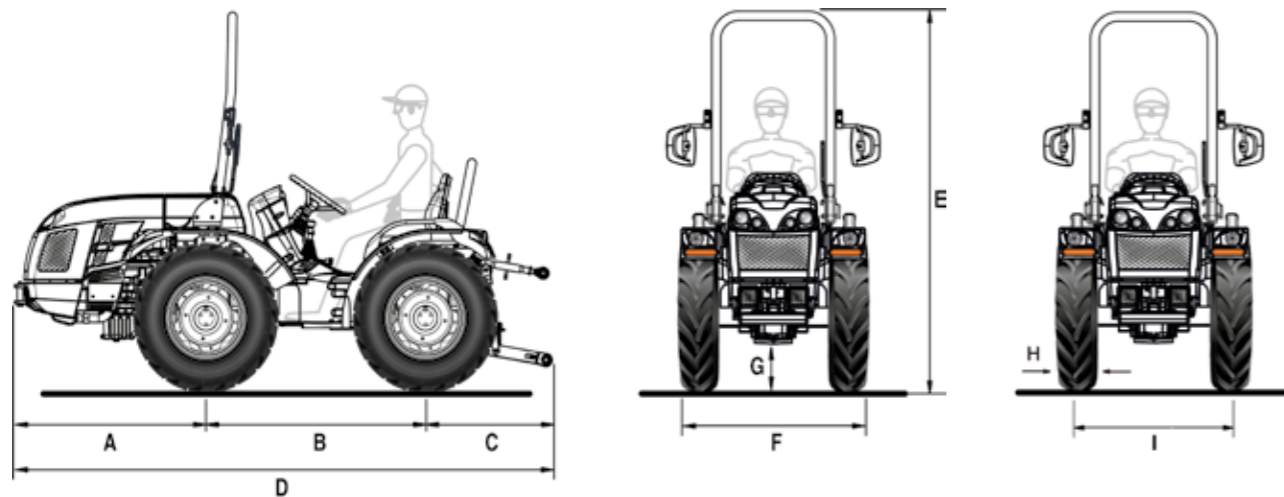

A	B	C	D	E min/max	F min/max	G min/max
968	1200	775	2943	1970 / 1990	989 / 1391	170 / 335

\* Dimensions in mm

	6.50-16 with adjustable rim	210/95 R16 (7.50-16) with adjustable rim	260/70 R16 with adjustable rim	240/70-15 Garden with fixed rim
H	183	209	258	253
I	806 / 1182	806 / 1182	882 / 1040	906 / 1082
F	989 / 1365	1015 / 1391	1140 / 1298	1159 / 1335

\* Dimensions in mm - min / max  
H = Tyre width - I = Wheel track - F = Tractor width

TECHNICAL FEATURES	INVICTUS 35 AR
<b>ENGINE</b>	Kubota D1105   Diesel indirect injection   Natural aspiration   3 cylinders   1123 cc   Liquid cooling   Stage V
Power	18.5 kW / 25 hp @3000 rpm   Max torque 71.5 Nm@2200 rpm
Tank capacity (l)	43
<b>CHASSIS</b>	Swinging integral chassis (±15°) OS-FRAME with central articulation
<b>DRIVE</b>	Permanent four-wheel drive
<b>TRANSMISSION</b>	Gearbox with easy gear engagement: 8 FWD + 4 REV speeds
Min/max travel speed (km/h)	1.5 / 30
Transmission clutch	Dry single disc
<b>DIFFERENTIAL</b>	Front and rear with simultaneous locking and mechanical control
<b>REAR PTO</b>	At 540 rpm and synchronised with forwarding speed
Engagement control	Mechanical
<b>HYDRAULIC SYSTEM</b>	Single-circuit
Hydraulic pump flow rate (l/min)	16.5
Maximum hydraulic pressure (bar)	125
<b>REAR CONTROL VALVES</b>	Mechanically controlled
Standard	1 double-acting (total 2 hydraulic outlets)
Optional	Up to 6 hydraulic outlets in total
<b>REAR LIFT</b>	Up/down lift, by two external cylinders
3-point implement hitch	With normal couplings cat. 1
Third point tie rod	With manual adjustment
Ball joint lifting capacity (kg)	950
<b>DRIVING POSITION</b>	Monodirectional
Steering wheel	Standard: fixed - Optional: height adjustable
Seat	Comfort seat with longitudinal, height and spring adjustment according to the operator's weight, safety belt and man-on-board sensor
<b>SERVICE BRAKES</b>	Drum brakes acting on rear wheels
Parking brake	Acting on service brakes
<b>STEERING</b>	Hydrostatic steering acting on the central joint
<b>SAFETY</b>	Front homologated roll-bar with gas spring for easy lowering and lifting
<b>DASHBOARD</b>	With analogue instrumentation complete with operating hours indicator, engine rpm, forwarding speed and warning lights
<b>ELECTRIC SYSTEM</b>	60 Ah / 12 V battery - 40 A alternator
Standard equipment	Street light and indicator system, front working lights, auxiliary power outlet on the dashboard (12V), rear 7-pin socket
<b>TYRES</b>	6.50-16 * 210/95R16 (7.50-16) * 260/70R16 * 240/70-15 Garden
<b>TOW HOOKS</b>	Standard: front and rear CUNA cat. B adjustable in height - Optional: rear tow hook EC approved
<b>RUNNING ORDER WEIGHT</b>	With roll-bar: 1040 kg
<b>ADDITIONAL OPTIONS</b>	Rear adjustable working light, beacon lamp, wheel weights kg 40 each.