

# VITHAR K90



Language





# VITHAR K90

## MUCH MORE ADVANTAGES

**VERSIONS WITH CENTRAL ARTICULATION (AR) OR STEERING WHEELS (RS)** to be performing and agile in rows of vineyards and orchards, greenhouses, nurseries and greens maintenance.

**REVERSIBLE DRIVING POSITION** (optional) to work with front implement, improving safety and operating comfort.

**MULTIPLE DISC CLUTCH IN OIL BATH** to guarantee longer life, reliability and soft and modular engagements.

**TRANSMISSION WITH OS-FRAME**, swinging up to 15° to guarantee stability and constant traction on very rough grounds.

**LAST GENERATION COMMON RAIL ENGINE** for more efficient combustion, improved performance and less fuel consumption.

**DOUBLE CIRCUIT HYDRAULIC SYSTEM WITH INDEPENDENT PUMPS**, heat exchanger and high oil flow to rear remote control valves.

**PLANETARY REDUCTION UNITS ON THE FOUR WHEELS** for the maximum power transmission, thanks to the three gears always engaged.

**PTO INDEPENDENT FROM THE GEARBOX AND SYNCHRONIZED WITH FORWARDING SPEED**. Multiple disc clutch in oil bath and electro-hydraulic control on the dashboard.

**ISODIAMETRIC WHEELS AND SHORT WHEEL-BASE** for steering radius at the top of the category.

**EXTREMELY COMPACT DIMENSIONS AND NARROW WHEEL TRACK** to easily move even in narrow spaces.

**TOP COMFORT FOR THE DRIVER**, with comfortable driver seat and controls easy to operate and ergonomically placed.

**TOTAL OPERATING SAFETY** thanks to the low centre of gravity, to 4WD and multiple disc brakes in oil bath.





# VITHAR K90 AR

## Data Sheet

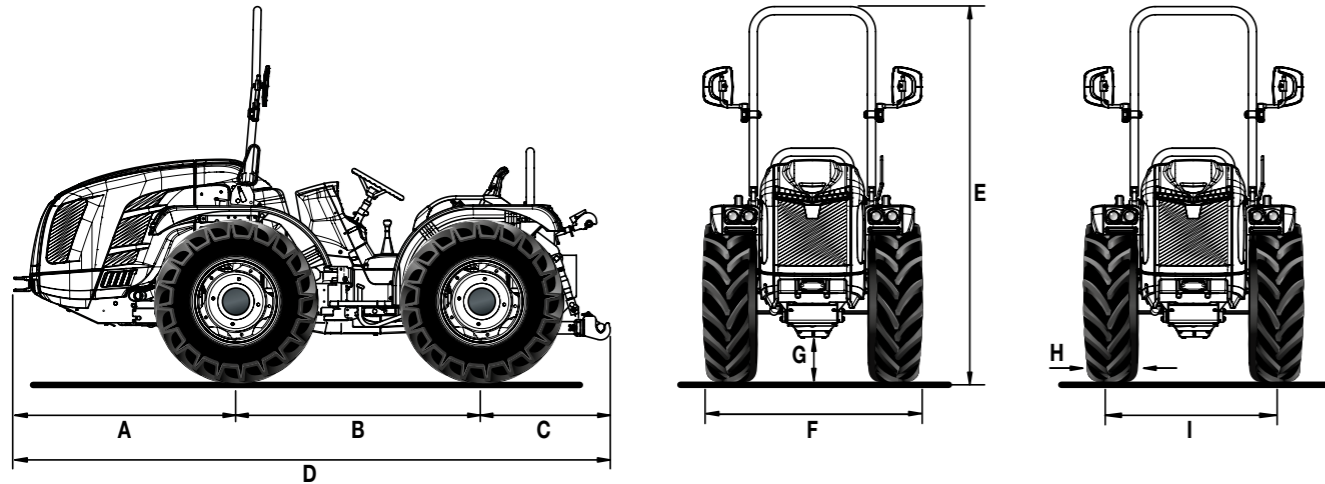

A	B	C	D	E min/max	F min/max	G min/max
1348	1450	927	3725	2254 / 2364	1125 / 1707	195 / 275

\* Dimensions in mm

	250/80-18	280/70 R18	280/70R18 Galaxy Garden	320/65 R18	250/85 R20
	with adjustable rim	with adjustable rim	with adjustable rim	with adjustable rim	with adjustable rim
H	240	282	282	320	245
I	912 / 1216	1002 / 1216	1002 / 1216	1002 / 1216	880 / 1334
F	1152 / 1456	1284 / 1498	1284 / 1498	1322 / 1536	1125 / 1579

	300/70 R20	300/70R20 Galaxy Garden	340/65 R20	31x15.50-15 XTC	31x15.50-15 STG
	with adjustable rim	with adjustable rim	with adjustable rim	with fixed rim	with fixed rim
H	286	286	343	368	394
I	984 / 1364	984 / 1364	984 / 1364	1006 / 1120	1120
F	1270 / 1650	1270 / 1650	1327 / 1707	1374 / 1488	1514

\* Dimensions in mm - min / max  
H = Tyre width - I = Wheel track - F = Tractor width

TECHNICAL FEATURES	VITHAR K90 AR
<b>ENGINE</b>	Kubota V3800-CR-T-EW03
No. of cylinders	4 in-line
Displacement (cc)	3,769
Intake	Turbo
Fuel system	Direct injection "Common rail"
Emissions compliance	Stage V
Balancing	Counter-balance shafts
Power (kW/hp)	54.6 / 75
Rated speed (rpm)	2,400
Max torque (Nm/rpm)	305.4 / 1,500
Engine speed management	Electronically regulated via a console with functions for: increase and decrease engine speed, memorize and recall the set speed, switch off and switch to minimum speed
Cooling	Liquid
Tank capacity (l)	54
<b>CHASSIS</b>	Swinging integral chassis (±15°) OS-FRAME with central articulation
<b>DRIVE</b>	Permanent four-wheel drive
<b>TRANSMISSION</b>	32-speed synchronised gearbox: 16 FWD and 16 REV with synchronised reverser
Transmission clutch	Multidisc in oil bath with hydraulic control
<b>DIFFERENTIAL</b>	Front and rear with simultaneous locking and electro-hydraulic control
<b>AXLES</b>	Front and rear with planetary reduction units
<b>REAR PTO</b>	Independent from the gearbox and synchronised with the forwarding speed. Negative safety hydraulic brake to stop the PTO
PTO clutch	Multidisc in oil bath with electro-hydraulic control
PTO rotation speed (rpm)	Standard: 540/540E - Optional: 540/1000
<b>HYDRAULIC SYSTEM</b>	Dual circuit with independent pumps and heat exchanger
Flow rate to the hydroguide and the electro-hydraulic controls (l/min)	33.1
Flow rate to the lift and the control valves (l/min)	27.7 (optional oversized pump with 49 l/min flow rate)
Maximum hydraulic pressure (bar)	180
<b>REAR CONTROL VALVES</b>	Mechanically controlled, standard free flow oil return
Standard	For lift by rams: 1 single-acting and 2 double-acting (total 6 hydraulic outlets) - For lift with draft and position control: 2 double-acting (total 5 hydraulic outlets)
Optional, replacing the standard ones	For lift by rams: 1 single-acting, 1 double-acting and 1 double-acting with float (total 6 hydraulic outlets) or 2 double-acting and 1 double-acting with float (total 7 hydraulic outlets) or 3 double-acting (total 7 hydraulic outlets). For lift with draft and position control: 1 single-acting and 1 double-acting (total 4 hydraulic outlets) or 1 double-acting and 1 double-acting with float (total 5 hydraulic outlets)
<b>REAR LIFT</b>	By two external rams. Standard: raising/lowering - Optional: position and draft control
3-point implement hitch	Standard: normal couplings cat. 1 and 2. Optional: quick-couplings cat. 1 and 2, L-shaped, arms adjustable in length and hooks adjustable in width
Third point tie rod	Standard: with manual adjustment - Optional: hydraulically controlled upper link and tie rod link arm
Ball joint lifting capacity (kg)	2300
<b>FRONT LIFT (optional)</b>	Two external rams with front protection and 2 double-acting control valves (total 4 hydraulic outlets)
Third point arms	Rigid with quick-couplings cat. 1
Lifting capacity (kg)	800
<b>DRIVING POSITION</b>	Monodirectional or Reversible with rotating platform and twin pedal assembly
Steering wheel	Height adjustable
Seat	With safety belt and man-on-board sensor. Standard: comfort seat with adjustable suspension according to the operator's weight. Optional: 'Kab' lowered seat
<b>SERVICE BRAKES</b>	Multidisc in oil bath with mechanical control, acting on the rear wheels
Parking brake	Acting on service brakes
<b>STEERING</b>	Hydrostatic steering acting on the central joint. Flow deviator for steering unit in Reversible version
<b>SAFETY</b>	Front homologated roll-bar with gas springs for easy lowering and lifting
<b>DASHBOARD</b>	With TFT colour display showing: hours of operation, engine rpm, forwarding speed, PTO rpm, particulate filter clogging level, instantaneous fuel consumption and current time. Analogue instrumentation complete with engine rpm, engine coolant temperature and fuel level indicator. Warning lights and acoustic alarm
<b>ELECTRIC SYSTEM</b>	Battery 100 Ah / 12 V - Alternator 95 A
Standard equipment	Rear 7-pin and 3-pin sockets
<b>TYRES</b>	250/80-18 * 280/70R18 * 280/70R18 Galaxy Garden * 320/65R18 * 250/85R20 * 300/70R20 * 300/70R20 Galaxy Garden * 340/65R20 * 31x15.50-15 XTC or STG
<b>TOW HOOKS (standard)</b>	Rear CUNA and front
Optional	Rear tow hook: EC approved or EC with Slider frame or CUNA with Slider frame or EC tow bar with Slider frame
<b>RUNNING ORDER WEIGHT with roll-bar (kg)</b>	2150
<b>ADDITIONAL OPTIONS</b>	Front bumper, beacon lamp, front weights 150 kg and wheel weights 50 kg each

# VITHAR K90 RS

## Data Sheet

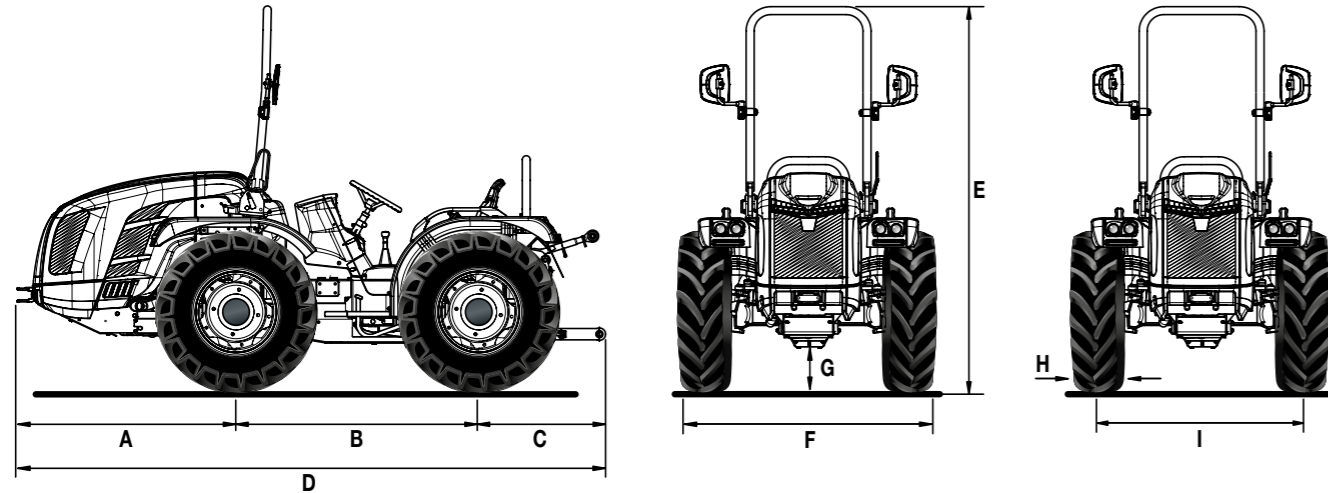

A	B	C	D	E min/max	F min/max	G min/max
1348	1450	927	3725	2254 / 2364	1368 / 1961	184 / 294

\* Dimensions in mm

	340/65 R18	280/70 R18	280/70R18 Galaxy Garden	320/65 R18	300/70 R20	300/70R20 Galaxy Garden
	with adjustable rim	with adjustable rim	with adjustable rim	with adjustable rim	with adjustable rim	with adjustable rim
H	343	270	270	320	286	286
I	1166 / 1470	1098 / 1538	1098 / 1538	1166 / 1470	1134 / 1618	1134 / 1618
F	1509 / 1813	1368 / 1808	1368 / 1808	1486 / 1790	1420 / 1904	1420 / 1904

	320/70 R20	340/65 R20	31x15.50-15 XTC	31x15.50-15 STG	13.6-16 Garden
	with adjustable rim	with adjustable rim	with fixed rim	with fixed rim	with fixed rim
H	316	343	368	394	391
I	1134 / 1618	1134 / 1618	1260 / 1374	1260 / 1374	1240 / 1400
F	1450 / 1934	1477 / 1961	1628 / 1742	1654 / 1768	1631 / 1791

\* Dimensions in mm - min / max  
H = Tyre width - I = Wheel track - F = Tractor width

TECHNICAL FEATURES	VITHAR K90 RS
<b>ENGINE</b>	Kubota V3800-CR-T-EW03
No. of cylinders	4 in-line
Displacement (cc)	3,769
Intake	Turbo
Fuel system	Direct injection "Common rail"
Emissions compliance	Stage V
Balancing	Counter-balance shafts
Power (kW/hp)	54.6 / 75
Rated speed (rpm)	2,400
Max torque (Nm/rpm)	305.4 / 1,500
Engine speed management	Electronically regulated via a console with functions for: increase and decrease engine speed, memorize and recall the set speed, switch off and switch to minimum speed
Cooling	Liquid
Tank capacity (l)	54
<b>CHASSIS</b>	Swinging integral chassis (±15°) OS-FRAME with steering wheels
<b>DRIVE</b>	Permanent four-wheel drive
<b>TRANSMISSION</b>	32-speed synchronised gearbox: 16 FWD and 16 REV with synchronised reverser
Transmission clutch	Multidisc in oil bath with hydraulic control
<b>DIFFERENTIAL</b>	Front and rear with simultaneous locking and electro-hydraulic control
<b>AXLES</b>	Front and rear with planetary reduction units
<b>REAR PTO</b>	Independent from the gearbox and synchronised with the forwarding speed. Negative safety hydraulic brake to stop the PTO
PTO clutch	Multidisc in oil bath with electro-hydraulic control
PTO rotation speed (rpm)	Standard: 540/540E - Optional: 540/1000
<b>HYDRAULIC SYSTEM</b>	Dual circuit with independent pumps and heat exchanger
Flow rate to the hydroguide and the electro-hydraulic controls (l/min)	33.1
Flow rate to the lift and the control valves (l/min)	27.7 (optional oversized pump with 49 l/min flow rate)
Maximum hydraulic pressure (bar)	180
<b>REAR CONTROL VALVES</b>	Mechanically controlled, standard free flow oil return
Standard	1 single-acting and 2 double-acting (total 6 hydraulic outlets)
Optional, replacing the standard ones	For lift by rams: 1 single-acting, 1 double-acting and 1 double-acting with float (total 6 hydraulic outlets) or 2 double-acting and 1 double-acting with float (total 7 hydraulic outlets) or 3 double-acting (total 7 hydraulic outlets). For lift with draft and position control: 1 single-acting, 1 double-acting and 1 double-acting with float (total 6 hydraulic outlets) or 3 double-acting (total 7 hydraulic outlets)
<b>REAR LIFT</b>	By two external rams. Standard: raising/lowering - Optional: position and draft control
3-point implement hitch	Standard: normal couplings cat. 1 and 2. Optional: quick-couplings cat. 1 and 2, arms adjustable in length or quick-couplings cat. 1 and 2, L-shaped, arms adjustable in length and hooks adjustable in width
Third point tie rod	Standard: with manual adjustment - Optional: hydraulically controlled upper link and tie rod link arm
Ball joint lifting capacity (kg)	2300
<b>FRONT LIFT (optional)</b>	Two external rams with front protection and 2 double-acting control valves (total 4 hydraulic outlets)
Third point arms	Rigid with quick-couplings cat. 1
Lifting capacity (kg)	800
<b>DRIVING POSITION</b>	Monodirectional or Reversible with rotating platform and twin pedal assembly
Steering wheel	Height adjustable
Seat	With safety belt and man-on-board sensor. Standard: comfort seat with adjustable suspension according to the operator's weight. Optional: 'Kab' lowered seat
<b>SERVICE BRAKES</b>	Multidisc in oil bath with mechanical control, acting on the rear wheels. Independent manoeuvring brakes acting on the rear wheels
Parking brake	Acting on service brakes
<b>STEERING</b>	Hydrostatic steering with two rams acting on the front wheels. Flow deviator for steering unit in Reversible version
<b>SAFETY</b>	Front homologated roll-bar with gas springs for easy lowering and lifting
<b>DASHBOARD</b>	With TFT colour display showing: hours of operation, engine rpm, forwarding speed, PTO rpm, particulate filter clogging level, instantaneous fuel consumption and current time. Analogue instrumentation complete with engine rpm, engine coolant temperature and fuel level indicator. Warning lights and acoustic alarm
<b>ELECTRIC SYSTEM</b>	Battery 100 Ah / 12 V - Alternator 95 A
Standard equipment	Rear 7-pin and 3-pin sockets
<b>TYRES</b>	280/70R18 * 280/70R18 Galaxy Garden * 320/65R18 * 300/70R20 * 300/70R20 Galaxy Garden * 320/70R20 * 340/65R18 * 340/65R20 * 31x15.50-15 XTC or STG * 13.6-16 Garden
<b>TOW HOOKS (standard)</b>	Rear CUNA and front
Optional	Rear tow hook: EC approved or EC with Slider frame or CUNA with Slider frame or EC tow bar with Slider frame
<b>RUNNING ORDER WEIGHT with roll-bar (kg)</b>	2150
<b>ADDITIONAL OPTIONS</b>	HDR hydraulic suspension with accumulator including: 1 flow regulator, 1 double-acting and 1 double-acting with float (control valves replacing the standard ones), front bumper, beacon lamp, front weights 150 kg and wheel weights 50 kg each



## THE SERVICES

---



### SPARE PARTS

A complete range of original spare parts, guaranteed directly by the manufacturer.



### ASSISTANCE

A team of specialists, well prepared and available to assure an efficient and resolving service.



### LUBRICANTS

We recommend to use the original PowerLube lubricants.



### FINANCIAL SERVICES

Financial solutions to meet the credit requirements.



M A D E I N I T A L Y

