



MA.TRA. 160



language



M A D E I N I T A L Y



MA.TRA. 160

A COMPLETE RANGE FOR GREEN PROFESSIONALS

Since its foundation in 1943, BCS has been designing and building grass mowing and greens maintenance machines.

The experience gained over the years and the success of these machines have allowed BCS to create a complete line of lawn mowers and heavy duty mowers specifically for this market segment.

Models in the Ma.Tra. range are in fact dedicated to demanding individuals for whom green care is their passion, or to professional maintainers who make intensive, daily use of them.

People and companies that use the machines on a continuous basis, demanding the best from them in terms of performance, reliability, comfort and economy of operation, all wrapped up in an innovative and attractive design.

MA.TRA. 160: COMPACT HYDROSTATIC LAWN MOWER

Ma.Tra. 160 is a hydrostatic lawn mower equipped with a 113 cm front cutting deck and grass collection basket for cutting grass on quality surfaces such as gardens and small parks.

Intended for demanding individuals and maintenance of semi-professional gardens, it can also be used to give the finishing touch to large areas and work under the canopy, in support to professional vehicles.

Caretakers and municipalities are in fact increasingly demanding compact, lightweight machines for the maintenance of areas where it would be impossible to operate with larger, heavier vehicles.

The advantage of having the cantilevered lawn mower also proves very useful when working under the low canopies of trees, plants and bushes.



SIMPLE AND PLEASANT USE

Ma.Tra. 160 is fitted with a two-cylinder Briggs&Stratton petrol engine that generates 15 hp.

The single-range hydrostatic transmission, with continuous speed variation from 0 to 10 km/h, allows easy and pleasant use of the Ma.Tra. 160, even by inexperienced operators.

A single pedal, equipped with a damper for smooth and jerk-free drive, controls both the forward and reverse movements.

The pedal-operated front differential lock with automatic disengagement when released, offers greater adherence of the wheels to the ground even in conditions of high humidity.

LARGE GRASS COLLECTION BASKET
with floor drain and automatic door closure.

STEERING WHEEL DRIVE SYSTEM
acting on the rear wheels.

COMFORTABLE DRIVING POSITION
with all controls within easy reach.

HYDROSTATIC TRANSMISSION
with pedal forward motion command.

15 HP TWO CYLINDER GASOLINE ENGINE.

DIFFERENTIAL LOCK
with pedal control for maximum traction.

CUTTING HEIGHT ADJUSTMENT
directly from the driver's seat.

FRONT LAWN MOWER
for perfect visibility of the work area.

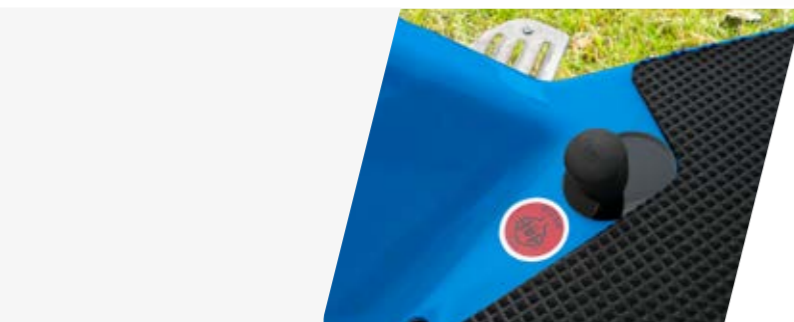
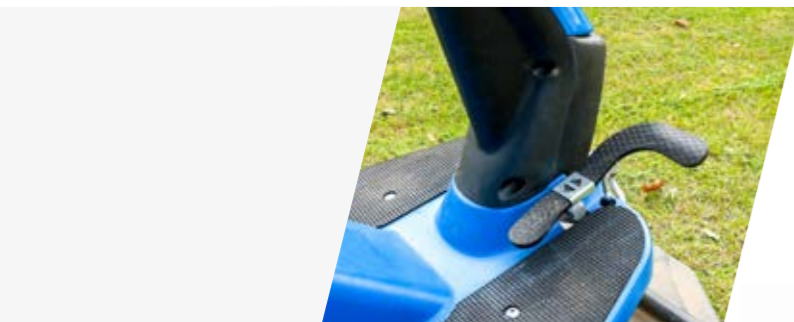

UNRIVALLED AGILITY AND COMFORT

The comfortable driving position features a cushioned, adjustable seat with a right armrest and ergonomically positioned controls that are easy to reach, making work pleasant and relaxing even after several hours of use.

Directly from the driver's seat the operator can operate the lawn mower, adjust the cutting height and unload the collection basket.



A digital hour meter displays:

- total hours worked,
- hours remaining to change the engine oil,
- hours remaining until greasing.

The steering wheel acts on the rear wheels and ensures minimum turning radii in order to easily mow even around plants and trees or in tight spaces.



PRECISE CUT

The 113 cm front-mounted, push-button-operated lawn mower allows perfect cuts in all conditions of use, even on uneven terrain.

Positioned cantilevered with respect to the operator, it offers a perfect view of the work area and a precise cut even under bushes and low branches.

The cutting height is adjusted (from a minimum of 30 mm to a maximum of 90 mm) directly from the driver's seat using a lever with 7 different positions.

The cutting unit can be transformed into a mulching deck using the dedicated optional kit that pulverises the cut grass and deposits it directly on the lawn.

THE 3 BLADES

The lawn mower consists of two counter-rotating blades and a third small front blade, which create forced ventilation of the air-grass flow inside the loading tunnel that leads to the collection basket.

Maintenance and cleaning are facilitated by the vertical positioning of the lawn mower, made possible by the support feet.



LARGE GRASS COLLECTION BASKET

The 300L collection basket is equipped with:

- ground tipping by button directly from the driver's seat,
- automatic closure of the door after unloading the grass,
- flow accelerator that optimises grass filling and compaction inside the collection basket.
- grass loading tunnel easily removable for practical and fast inspection and cleaning.

When the collection basket is filled, an audible alarm warns the operator and at the same time a sensor disengages the rotation of the blades to prevent clogging of the loading tunnel.



TECHNICAL FEATURES

| | |
|---|---|
| ENGINE | Gasoline Briggs & Stratton Vanguard V-Twin |
| No. of cylinders | 2 |
| Displacement (cc) | 479 |
| Power (kW/hp) | 11 / 15 |
| Max torque (Nm/rpm) | 30.6 / 2,600 |
| Starter | Electric, via ignition key on the dashboard |
| Fuel tank capacity (l) | 7.5 - of which 1.5 reserve |
| Hourly consumption (l/h) | 3,5 |
| TRANSMISSION | Single-range hydrostatic |
| Advance command | Pedal |
| Forward speed (km/h) | FW: 0 - 10 / REV: 0 - 7.5 |
| Drive | 2WD |
| Differential | With pedal lock |
| PTO clutch | Electromagnetic with blade brake |
| Parking brake | Disc, lever-operated |
| DRIVE SYSTEM | Steering wheel, acting on the rear wheels |
| Internal steering diameter (mm) | 320 |
| Seat | Adjustable and shock-absorbing, with armrest |
| FRONT LAWN MOWER | With three blades set up for collection |
| Working width (mm) | 1,130 |
| Overall width (mm) | 1,190 |
| Cutting height adjustment | By lever directly from the driver's seat. 30 to 90 mm |
| Mulching kit | On request |
| GRASS COLLECTION BASKET | With flow accelerator |
| Capacity (l) | 300 |
| Door closure | Double magnetic |
| Tipping | On the ground, directly from the driver's seat with push-button control |
| TYRES | Garden profile. Front: 18x9.50-8 * Rear: 13x6.50-6 |
| INDICATIVE WORKING CAPACITY (m2/h) | 6,000 |
| Rear tow hitch | Standard |

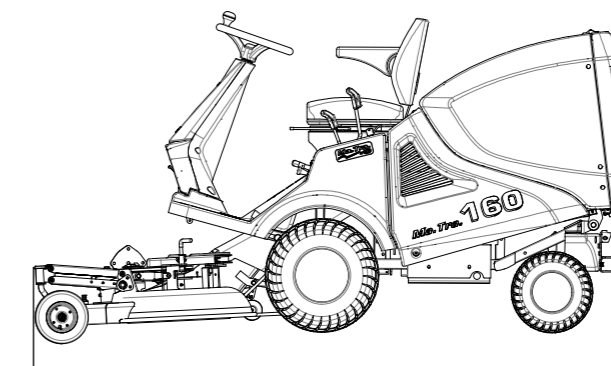
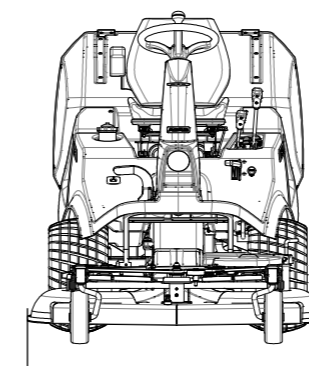

DIMENSIONS

| | |
|---------------|----------|
| LENGTH | 2,380 mm |
| WIDTH | 1,190 mm |
| HEIGHT | 1,230 mm |
| WEIGHT | 340 kg |

THE SERVICES



SPARE PARTS

A complete range of original spare parts, guaranteed directly by the manufacturer.



ASSISTANCE

A team of specialists, well prepared and available to assure an efficient and resolving service.



WARRANTY

A precise certainty for the customer's satisfaction:
2-year warranty included in the price.



LUBRICANTS

We recommend to use the original PowerLube lubricants.



BCS S.p.A.
Viale Mazzini, 161 - 20081 Abbiategrasso
Tel. +39 02 94821 | info@bcs-ferrari.it
www.bcsagri.com



M A D E I N I T A L Y