

TECHNICAL FEATURES

ENGINE	Gasoline Briggs & Stratton Vanguard V-Twin
No. of cylinders	2
Displacement (cc)	479
Power (kW/hp)	11 / 15
Max torque (Nm/rpm)	30.6 / 2,600
Starter	Electric, via ignition key on the dashboard
Fuel tank capacity (l)	9.5 - of which 1 reserve
Hourly consumption (l/h)	3,5
TRANSMISSION	Single-range hydrostatic
Advance command	Lever
Forward speed (km/h)	FW: 0 - 9.5 / REV: 0 - 7.5
Drive	2WD
Differential	With pedal lock
PTO clutch	Electromagnetic with blade brake
Emergency brakes	Drum on front wheels, pedal-operated
Parking brake	Disc on rear axle, with lever control
DRIVE SYSTEM	Steering wheel, acting on the front wheels
Internal steering diameter (mm)	970
Seat	Adjustable and shock-absorbing, with armrests
UNDER-BELLY HEAVY DUTY MOWER	Single-blade rear discharge
Working width (mm)	850
Overall width (mm)	1,030
Cutting height adjustment	By lever directly from the driver's seat. Six positions from 50 to 85 mm
TYRES	Tractor profile. Front: 13x5.00-6 * Rear: 16x6.50-8
INDICATIVE WORKING CAPACITY (m2/h)	6,000
Rear tow hitch	Standard

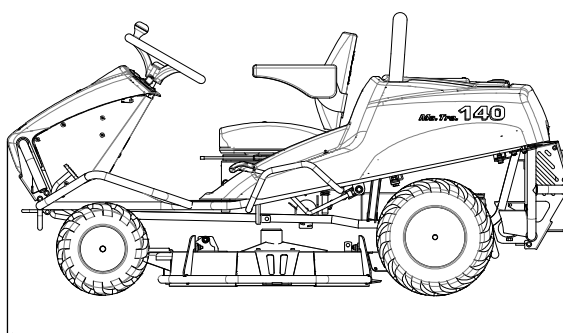
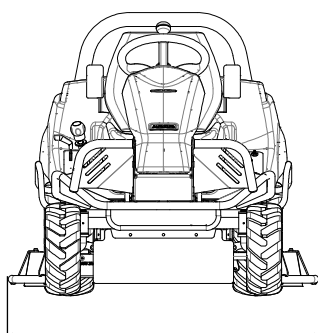

DIMENSIONS

LENGTH	2,000 mm
WIDTH	1,030 mm
HEIGHT	960 mm
WEIGHT	280 kg