

TECHNICAL FEATURES

ENGINE	Direct injection diesel - Stage V
Model	Yanmar 3TNV82A
No. of cylinders	3
Displacement (cc)	1331
Intake	Natural
Maximum power at 2800 rpm (kW/hp)	18.9 / 26
Max torque (Nm/rpm)	83 / 1680
Cooling system	With self-cleaning dual-element air/oil mesh radiator
Tank capacity (l)	46
TRANSMISSION	Hydrostatic double range (slow for work / fast for transfer)
Forward speed (km/h)	Slow range: 0 to 10 km/h - Fast range: 0 to 20 km/h
Forward motion command	Double pedal (forward/reverse)
DRIVE	Four-wheel drive with automatic disengagement of rear-wheel drive by engaging the fast transfer range
DIFFERENTIALS	Front, rear and centre anti-scalc. The front differential is with pedal lock and at the same time you also get the centre differential lock
POWER TAKE-OFF	Rated speed: 2600 rpm
Power take-off clutch	Electro-hydraulic
HYDRAULIC LIFT	Two-cylinder with two-point hitch
STEERING	Steering wheel with power steering acting on the rear wheels
STEERING WHEEL	Adjustable with tilt steering column
Minimum turning radius (mm)	400 (internal pneumatic) - Zero with the aid of the independent brakes
CONTROL INSTRUMENTATION	Integrated in the dashboard on the steering column
SERVICE BRAKES	Independent drums on the front wheels with separate pedal control and latch to make them integral during road traffic
Parking brake	Acting on service brakes
SEAT	Professional adjustable and sprung, with high backrest, armrests and safety belts
TYRES	Front 26x12.00-12 with Garden or Terra Tyre profile * Rear 18x8.50-8 with Garden profile
STANDARD EQUIPMENT	Homologated folding roll-bar, road-legal LED lights, front hydraulic socket kit

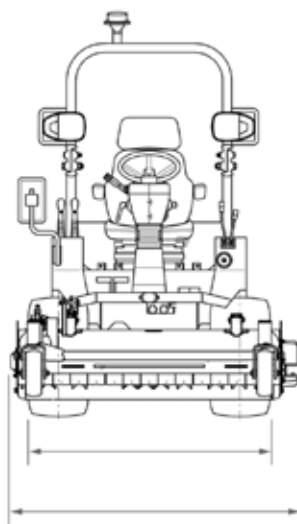
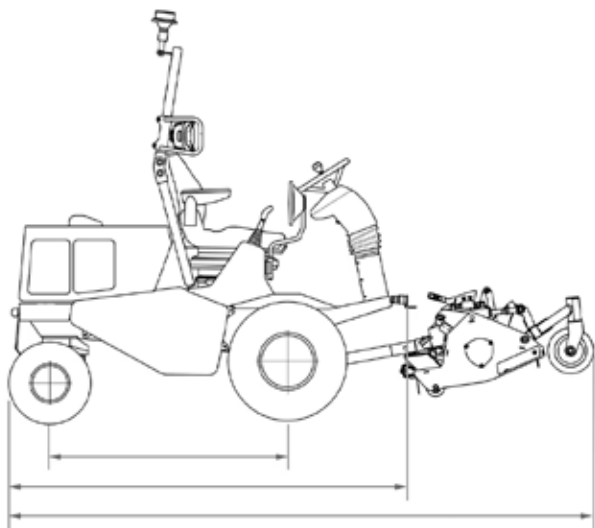

DIMENSIONS

LENGTH	2220 mm (without attachment) 3280 mm (with MUSTER) 2930 mm (with BLADERUNNER)
WIDTH	1300 mm (without attachment) 1590 mm (with MUSTER) 1560 mm (with BLADERUNNER)
HEIGHT	2360 mm
GROUND CLEARANCE	180 mm
WHEELBASE	1300 mm
EMPTY WEIGHT	1148 kg (without attachment) 1441 kg (with MUSTER) 1374 kg (with BLADERUNNER)