

VOLCAN 85 MT - MODEL YEAR 24

Data Sheet

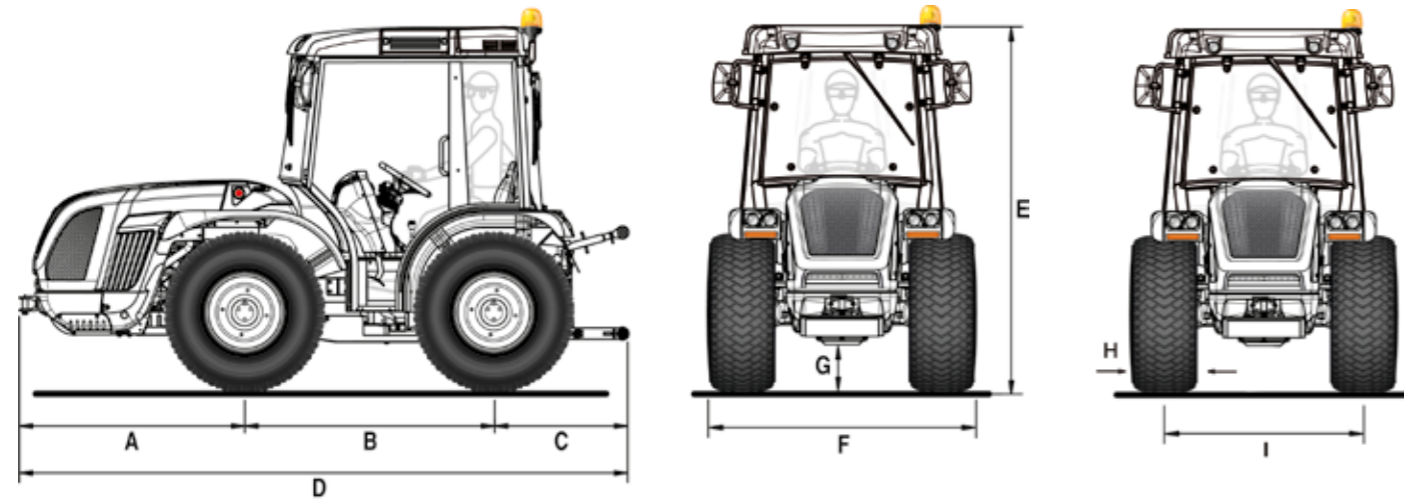

A	B	C	D	E min/max	F min/max	G min/max
1365	1495	930	3790	2070 / 2180	1697 / 1961	161 / 271

* Dimensions in mm

	31x15.50-15 XTC	31x15.50-15 STG	440/50-17 All-Ground	340/65 R20
	with fixed rim	with fixed rim	with fixed rim	with adjustable rim
H	368	394	431	343
I	1510	1510	1476	1354 / 1618
F	1878	1904	1907	1697 / 1961

* Dimensions in mm - min / max
H = Tyre width - I = Wheel track - F = Tractor width

TECHNICAL FEATURES	VOLCAN 85 MT - MODEL YEAR 24
ENGINE	Kohler KDI 2504 TCR Diesel common rail direct injection Turbo intercooler 4 cylinders 16 valves 2482 cc Liquid cooling Stage V
Power	55,4 kW / 75,3 hp @2300 rpm Max torque 300 Nm@1500 rpm
Engine speed management	Electronic engine speed control with hand throttle control knob and push button with set speed storage/recall/exclusion function
Self Cleaning System™ (standard)	Automatic radiator and engine intake grille cleaning system to prevent overheating
CHASSIS	Swinging integral chassis (±15°) OS-FRAME with steering wheels
DRIVE	Four-wheel drive. Front-wheel drive disengagement with electro-hydraulic control
TRANSMISSION	32-speed synchronised gearbox: 16 FWD and 16 REV with synchronised reverser
Min/max travel speed (km/h)	0.7 / 40
POWER SHUTTLE EASYDRIVE® (optional)	Electronically controlled electro-hydraulic with lever positioned to the left of the steering wheel and two available reversing modes: slow reverse and quick reverse
Transmission clutch	Multidisc in oil bath with electronically-managed and proportional hydraulic control. Power Clutch System button for engaging gears and reverser without using the clutch pedal. PRO-ACT System clutch pedal with Easy Plus™ assisted engagement. Smart Brake & Go function for automatic clutch management only with the brake pedal.
DIFFERENTIAL	Front and rear. Differential lock: front and rear simultaneously or rear only with electro-hydraulic control
AXLES	Front and rear with planetary reduction units
REAR PTO	Independent from the gearbox and synchronised with the forwarding speed. Negative safety hydraulic brake to stop the PTO
PTO clutch	Multidisc in oil bath with electro-hydraulic control
PTO rotation speed (rpm)	Standard: 540/1000 - Optional: 540/540E
HYDRAULIC SYSTEM	Dual circuit with independent pumps and heat exchanger
Hydraulic pump flow rate of the power steering and electro-hydraulic controls (l/min)	33,5
Hydraulic pump flow rate of the lift and control valves (l/min)	29,5
Maximum hydraulic pressure (bar)	180
REAR CONTROL VALVES	Mechanically controlled
Standard	3 double-acting and 1 double-acting with float (total 8 hydraulic outlets)
Joystick (optional)	Proportional electronic joystick with new ergonomic grip for controlling the rear lift with Dual Floating System® (and front lift if present) and rear control valves consisting of: 1 single-acting, 2 double-acting and 1 double-acting with float (control valves replacing standard ones) without free flow oil return (total 7 hydraulic outlets). Potentiometer for adjusting the hydraulic flow rate. Remote PTO engagement control. Storage armrest
REAR LIFT	Up/down lift with four external cylinders and Dual Floating System® hydraulic suspension
3-point implement hitch	Standard: Quick-couplings cat. 1 and 2, L-shaped, arms adjustable in length and hooks adjustable in width - Optional: Quick-couplings cat. 1 and 2, arms adjustable in length
Third point tie rod	Standard: with manual adjustment - Optional: hydraulically controlled upper link and tie rod link arm
Ball joint lifting capacity (kg)	2300
FRONT LIFT (optional)	Two-cylinder, complete with front bumper and 4 front hydraulic outlets (replicated from the rear)
Third point arms	Rigid with quick-couplings cat. 1
Lifting capacity (kg)	800
DRIVING POSITION	Reversible with wide rotating platform suspended on silent blocks. Suspended pedals mounted on the rotating control tower
Steering wheel	Tilt adjustable
Seat	With gas spring for easy tipping, safety belt and man-on-board sensor. Standard: comfort seat with armrest and adjustable spring tension according to the operator's weight - Optional: 'Grammer' or 'Cobo' pneumatic seat
SERVICE BRAKES	Oil bath discs with hydrostatic control, acting on the four wheels with automatic engagement of the 4-wheel drive. Independent manoeuvring brakes acting on the rear wheels
Parking brake	Automatic and independent Brake-Off acting as emergency brake with proportional action
STEERING	Hydrostatic steering acting on the front wheels. Flow deviator for steering unit
SAFETY	Standard: 6-post semi-cab and beacon lamp
CABIN (optional)	SPACE CLIMA model, homologated and soundproof. Six-post monocoque frame mounted on silent blocks. Fully glazed doors and cloth seat. LED beacon lamp and rear lights. A/C, ventilation and heating system. Car radio preparation. Optional: activated carbon filters
DASHBOARD	Instrument panel with analogue gauges and TFT digital colour display. Warning lights and horn
ELECTRIC SYSTEM	Battery 80 Ah / 12 V - Alternator 95 A
Standard equipment	Vehicle Control Unit, full LED street lights and indicator system, front LED working lights, two USB sockets on the dashboard, rear 7-pin and 3-pin sockets
TYRES	31x15.50-15 XTC * 31x15.50-15 STG * 440/50-17 All-Ground * 340/65R20
TOW HOOKS	Standard: front and rear CUNA cat. C adjustable in height - Optional: rear tow hook EC approved or EC with Slider frame or CUNA with Slider frame or EC tow bar with Slider frame
RUNNING ORDER WEIGHT	With semi-cab: 2420 kg - With cabin: 2500 kg
ADDITIONAL OPTIONS	Front bumper, front weights 150 kg total and wheel weights 50 kg each, silver and bordeaux 'Special Edition' livery