

e-VANGUARD AR

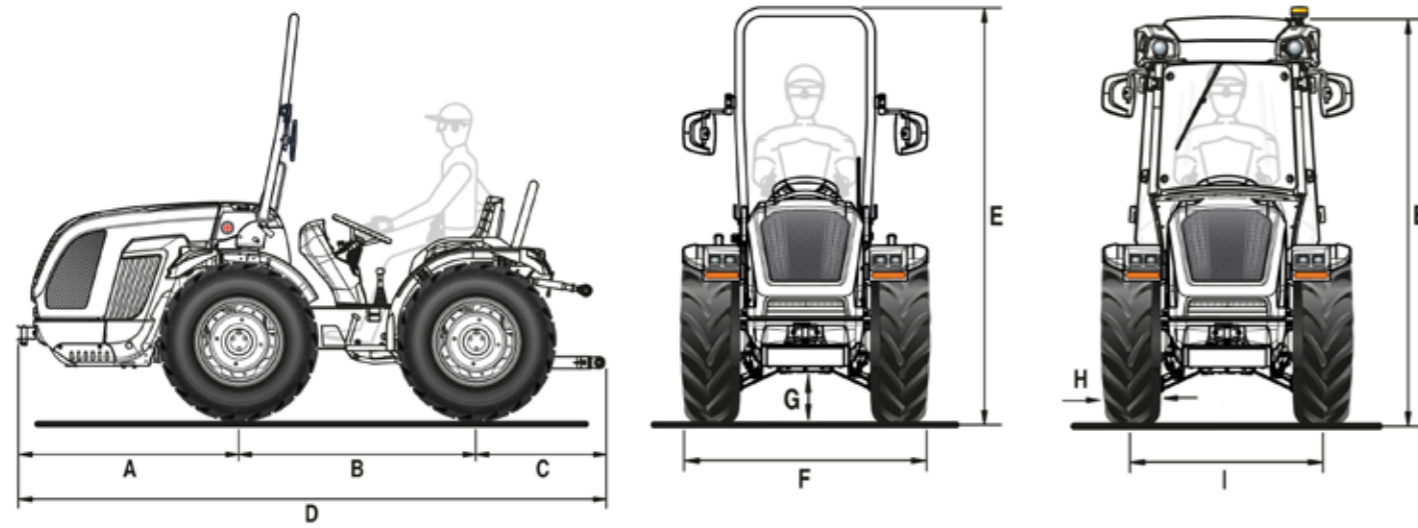

A	B	C	D	E min / max (with roll-bar)	E min / max (with cab)	F min / max	G min / max
1248	1390	779	3417	2195 / 2270	2061 / 2106	1002 / 1438	200 / 275

Dimensions in mm

	8.25-16	210/95 R16	250/80-18	280/70 R18	280/70 R18 Garden
	with adjustable rim	with adjustable rim	with adjustable rim	with adjustable rim	with adjustable rim
H	212	208	240	282	282
I	794 / 1110	794 / 1110	865 / 1107	869 / 1119	869 / 1119
F	1006 / 1322	1002 / 1318	1105 / 1347	1151 / 1401	1151 / 1401

	320/65 R18	260/70 R20	31x15.50-15 XTC	31x15.50-15 STG	33x15.50-15 XTC
	with adjustable rim	with adjustable rim	with fixed rim	with fixed rim	with fixed rim
H	319	258	368	394	391
I	931 / 1119	846 / 1120	1003	1003	1003
F	1250 / 1438	1104 / 1378	1371	1397	1394

Dimensions in mm - min / max
H = Tyre width - I = Wheel track - F = Tractor width

TECHNICAL FEATURES	e-VANGUARD AR
ENGINE	Electric Total installed electrical power 41 kW
Batteries	Lithium Voltage 48 V Capacity 36 kWh
Autonomy	3 to 6 hours depending on application and working conditions
Charging time	Battery charging time with 6 kWh input: approx. 3 hours (20 to 80%) - approx. 5 hours (0 to 100%)
CHASSIS	Swinging integral chassis (±15°) OS-FRAME with central articulation
DRIVE	Permanent four-wheel drive
TRANSMISSION	24-speed synchronised gearbox: 12 FWD and 12 REV with synchronised reverser
Min/max travel speed (km/h)	0.6 / 35
Transmission clutch	Multidisc in oil bath
DIFFERENTIAL	Front and rear with simultaneous locking and electro-hydraulic control
AXLES	Front and rear with planetary reduction units
REAR PTO	Independent from the gearbox and synchronised with forwarding speed. Negative safety hydraulic brake to stop the PTO
PTO clutch	Multidisc in oil bath with electro-hydraulic control
PTO rotation speed (rpm)	540/540E
HYDRAULIC SYSTEM	Dual circuit with dedicated electric engine
Hydraulic flow rate of the power steering and electro-hydraulic controls (l/min)	17
Hydraulic flow rate of the lift and control valves (l/min)	23 (optional circuit with increased flow rate 33.5 l/min)
Maximum hydraulic pressure (bar)	180
REAR LIFT	By two external cylinders. Standard: up/down lift - Optional: position and draft-controlled
3-point implement hitch	Standard: normal couplings cat. 1 - Optional: quick-couplings cat. 1 and 2, L-shaped, arms adjustable in length and hooks adjustable in width
Third point tie rod	With manual adjustment
Ball joint lifting capacity (kg)	1510
REAR CONTROL VALVES	Mechanically controlled
Standard	With rear up/down lift: 1 double-acting and free flow oil return (total 3 hydraulic outlets) - With position and draft-controlled rear lift: 1 double-acting, 1 multifunctional double-acting and free flow oil return (total 5 hydraulic outlets)
Optional	With rear up/down lift: up to 7 hydraulic outlets in total and free flow oil return
Joystick (optional)	Proportional electronic control of rear lift and control valves consisting of: 1 continuous flow with adjustable flow rate and free flow oil return, 3 double-acting (replacing the standard ones) and circuit with increased flow rate (total 8 hydraulic outlets)
DRIVING POSITION	Monodirectional or reversible with rotating platform suspended on silent blocks and twin pedal assembly
Steering wheel	Height adjustable
Seat	Comfort seat with adjustable suspension according to the operator's weight, safety belt and man-on-board sensor
SERVICE BRAKES	Multidisc in oil bath with mechanical control, acting on the rear wheels
Parking brake	Acting on service brakes
STEERING	Hydrostatic steering acting on the central joint. Flow deviator for steering unit in the reversible version
SAFETY	Front homologated roll-bar with gas spring for easy lowering and lifting
CABIN (optional)	VISTA CLIMA model, homologated and soundproofed with monocoque body with a 4-upright suspended on silent block. Ventilation, heating and air-conditioning system. Fabric seat, car radio preparation, LED beacon lamp, front and rear working lights
DASHBOARD	Instrument panel with analogue gauges and TFT digital colour display. Remaining charge indicator, warning lights and horn
Standard equipment	Vehicle Control Unit, LED street light and indicator system, single-pole dashboard socket, rear 7-pin socket
TYRES	Tractor: 8.25-16 * 210/95R16 * 250/80-18 * 280/70R18 * 320/65R18 * 260/70R20 Garden: 280/70R18 Terra Tyre: 31x15.50-15 XTC * 31x15.50-15 STG * 33x15.50-15 XTC
TOW HOOKS	Standard: front and rear CUNA cat. B adjustable in height - Optional: rear tow hook EC approved or EC with Slider frame or CUNA with Slider frame or EC tow bar with Slider frame
RUNNING ORDER WEIGHT	With roll-bar: 1660 kg - With cabin: 1740 kg
ADDITIONAL OPTIONS	Recharge cable kit 25 A 3 phases 16.5 kW with 6 adapters, front bumper, beacon lamp, front LED working lights, rear adjustable working light, front weights 110 kg total and wheel weights 45 kg each