



VALIANT 600
AR/RS



language



MUCH MANY ADVANTAGES WITH VALIANT 600



OS-FRAME TRANSMISSION
in order to optimize mechanical efficiency and stability even on rough terrain.



REVERSIBLE DRIVING POSITION
optional on all models.

EXCELLENT DRIVING CONDITIONS
with ergonomic controls placed to be easily found and activated by the operator.



KOHLER ENGINE
with direct injection: low fuel consumption and excellent performance.



LOOK
modern and captivating.



PLANETARY GEARS
on both axles in order to ensure maximum power transmission and durability.



SERVICE BRAKES
oil immersed multidisc.



A proposal for all your needs

The **Valiant 600** are isodiametric tractors extremely versatile and reliable. They have been studied in detail for specific use in vineyards, orchards, greenhouses and, in general, for specialized crops where the tractor's structural characteristics are of fundamental importance in allowing work to be done in a practical way. The excellent steering radius, the four-wheel drive that optimises the power that is transmitted to the wheels and a compact and secure alignment, allow the **Valiant 600** provide performances at the top of their category, along with excellent levels of productivity and low operating costs.



HYDRAULIC SYSTEM
high performance hydraulic system to adopt a great deal of hydraulically-fired equipments.



PTO INDEPENDENT
and synchronized with the gearbox.

SHORT WHEELBASE
in order to reduce turning radius so as to be able to move with maximum ease even in small spaces.





VALIANT 600 AR

Isodiametric tractors, monodirectional or reversible, with central articulation

The **Valiant 600 AR** are specialized tractors, born to be used in particularly narrow areas: row cultivations, vineyards, orchards, greenhouses and nurseries. They are particularly performing machines, thanks to the isodiametric wheels and the frame with central articulation. The limited steering radius, the reversibility of the driving position (optional) and the constant adherence to the ground make the **Valiant 600 AR** multi-purposes and versatile machines. In spite of the limited dimensions, the driving position is particularly comfortable with easily reachable controls also in the reversed position.



VALIANT 600 RS

Isodiametric tractors, monodirectional or reversible, with steering wheels

The **Valiant 600 RS** are multi-purpose specialized tractors, particularly performing in vineyards, orchards and greens maintenance. The low hub and the all-wheel drive assure stability and adherence to the ground and allow the **Valiant 600 RS** to work both on flat and sloping grounds. The engine power together with the perfect weight distribution on the axles make them safe and trusty supporters. The reversible driving position (optional) allows to operate practically and safe both with rear-and front-mounted attachments.

Kohler KDi 2504M: compact, reliable and performing

The **Valiant 600** are mounting a 4-cylinder, 2.5 liter Kohler engine developing 49 horsepower with a vigorous torque of 170 Nm corresponding to just 1500 rpm.



| VALIANT | Type | Power (kw/hp) | No. of cylinders | Displacement | Aspiration | Cooling |
|---------|-----------|---------------|------------------|--------------|------------|---------|
| 600 | KDi 2504M | 36 / 49 | 4 | 2482 | Natural | Water |

PLUS

The new Synchro 24-speed gearboxes (12 forward + 12 reverse) assure a maximum speed of more than 30 km/h for both driving directions, with synchronized inverter. Logical speed sequence, no overlaps throughout all ranges, always allows right gear selection for the tasks for which the tractor is intended to, enabling fuel

saving and an overall high operating quality. The "Long-life" clutch designed for **Valiant 600** is a wet multiple discs one, allowing easy and gradual engagements. It is mounted in the transmissions system to reduce engine overhang and the tractor length and it does not require maintenance.



GRAPH OF THE SPEEDS IN Km/h - ENGINE SPEED: 2600 RPM
The graph highlights the perfect progression of the ratios, without any speed overlapping between the ranges.

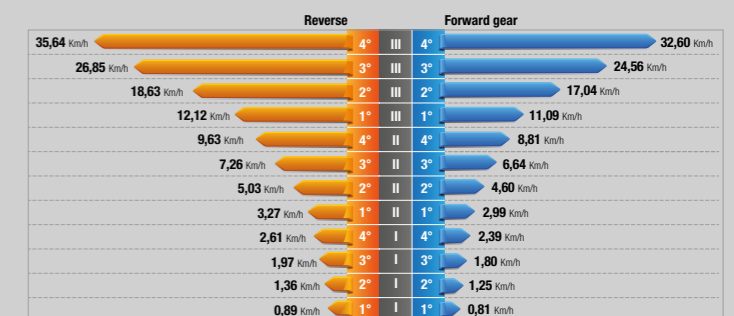

AN ABSOLUTELY UNIQUE CONTEXT



PLUS

High performing hydraulic system

The hydraulic system is a dual circuit, powered by two independent pumps: one pump controls the power steering and electro-hydraulic control (maximum flow rate 15,3 l/min), the other pump controls the lift and the distributors (maximum flow rate 25,6 l/min). Operation hydraulic pressure is 180 bar.



Lever strength

The solid rear hydraulic lift, with its high lifting capacity, relies on multi-purpose practical and versatile connections designed to adapt in a fast and simple way to all marketed equipments. Lifting arms are equipped with normal connections, quick couplers and quick couplers with hook angular lateral adjustment.



Standard couplers



Quick couplings



L-shaped quick couplings

Transmission and high quality axles

The **Valiant 600** are provided with OS-Frame transmissions awarding the highest tractor maneuverability and the best mechanical output.

The joint in the middle of the machine lets the front axle oscillate up to 15° with respect to the rear axle, stabilizing the machines on steep terrain.

The 4-wheel drive allows absolute safety on every terrain, exploiting to the maximum the machine's designed towing and security outfits.

The distribution of the weights on the axles, 40% on the rear and 60% on the front, is proved optimal once the rear lifting equipment is mounted.

The **Valiant 600** are equipped with planetary gear axles in order to ensure maximum power transmission and durability.



PTO with maximum power needed to transmission

The rear PTO is independent from the gearbox and synchronized with all progress speeds. PTO at 540 rpm can be engaged in a practical and safe way through an electro-hydraulic control.

PLUS

Reserved to the driver

The driving position is custom-fitted on the driver with ergonomic controls placed to be easily found and activated by the operator. The reversibility can be achieved in just a few seconds thanks to the rotating console which allows the driving position consisting of seat-steering wheel-instrument panel, to rotate by 180°, so that the operator can practically and rationally work both with rear and front attachments.

The braking system with multi-disc wet brakes, the roll-bar and the safety belts on the seat assure the highest safety of operation in every conditions.

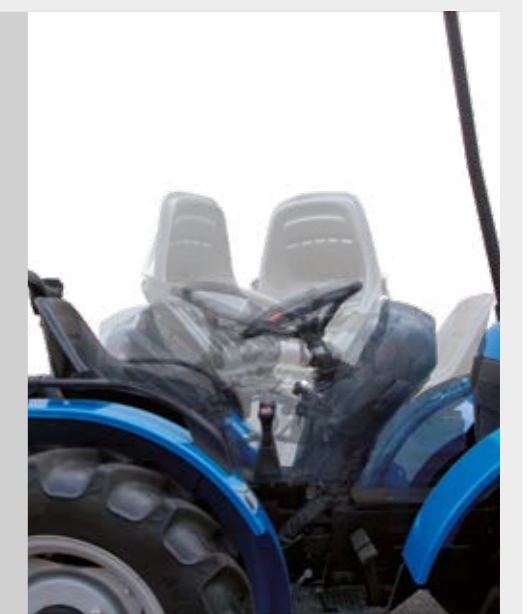

VALIANT 600 AR

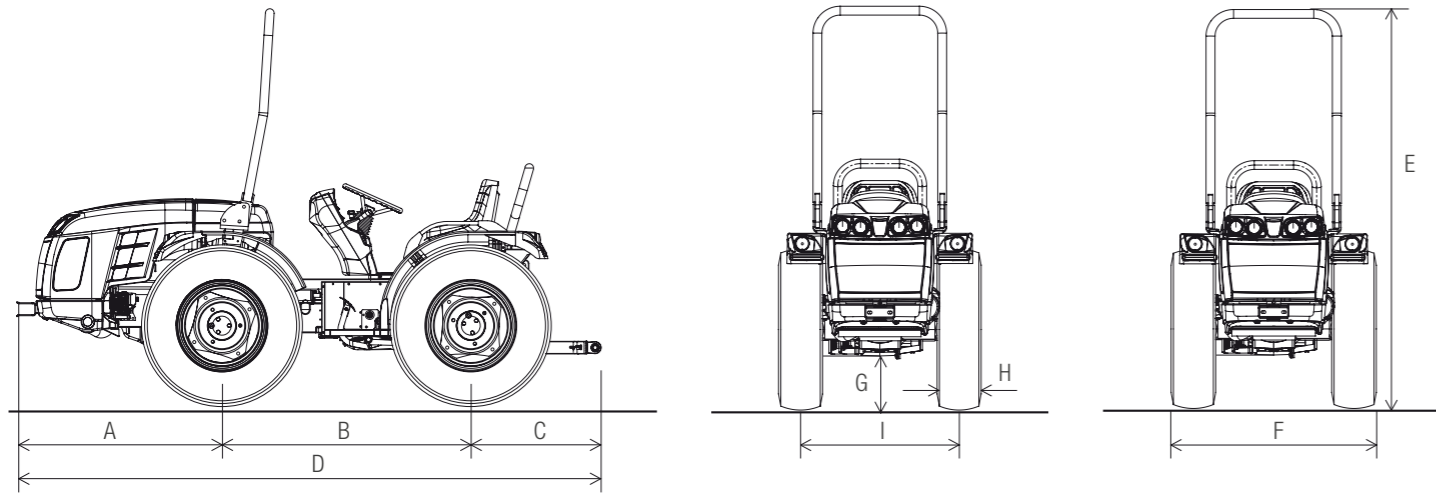

| A | B | C | D | E min / max | F min / max | G min / max |
|------|------|-----|------|----------------|----------------|----------------|
| 1157 | 1340 | 779 | 3276 | 2145 / 2220 | 1002 / 1438 | 220 / 270 |

Dimensions in mm

| | 8.25-16 WITH ADJUSTABLE RIM | 210/95 R16 (7.50-16) WITH ADJUSTABLE RIM | 250/80-18 WITH ADJUSTABLE RIM | 280/70 R18 WITH ADJUSTABLE RIM | 280/70R18 Garden WITH ADJUSTABLE RIM |
|----------|--------------------------------|---|----------------------------------|-----------------------------------|--|
| H | 212 | 208 | 240 | 282 | 282 |
| I | 794 / 1110 | 794 / 1110 | 865 / 1107 | 869 / 1119 | 869 / 1119 |
| F | 1006 / 1322 | 1002 / 1318 | 1105 / 1347 | 1151 / 1401 | 1151 / 1401 |

| | 320/65 R18 WITH ADJUSTABLE RIM | 260/70 R20 WITH ADJUSTABLE RIM | 31x15.50-15 XTC WITH FIXED RIM | 31x15.50-15 STG WITH FIXED RIM | 33x15.50-15 XTC WITH FIXED RIM |
|----------|-----------------------------------|-----------------------------------|-----------------------------------|-----------------------------------|-----------------------------------|
| H | 319 | 258 | 368 | 394 | 391 |
| I | 931 / 1119 | 846 / 1120 | 1003 | 1003 | 1003 |
| F | 1250 / 1438 | 1104 / 1378 | 1371 | 1397 | 1394 |

Dimensions in mm - min / max
H = Tyre width - I = Wheel track - F = Tractor width

| VALIANT 600 AR | |
|---|--|
| ENGINE | 4-cycle diesel engine with direct injection |
| Manufacturer | Kohler |
| Model | KDi 2504M |
| Number of cylinders | 4 |
| Displacement cm ³ | 2482 |
| Suction | Naturally aspirated |
| Power KW/HP | 36 / 49 |
| Nominal speed (rpm) | 2600 |
| Maximum tractor torque (Nm/rpm) | 170 / 1500 |
| Cooling | Water |
| Tank capacity (l.) | 45 |
| CHASSIS | Swinging integral chassis (±15°) OS-FRAME with central articulation |
| DRIVE | Permanent four-wheel drive |
| TRANSMISSION | 24-speed synchronised gearbox: 12 FWD and 12 REV with synchronised reverser |
| Transmission clutch | Multidisc in oil bath |
| DIFFERENTIAL | Front and rear with simultaneous locking and electro-hydraulic control |
| AXLES | Front and rear with planetary reduction units |
| REAR PTO | Independent from the gearbox and synchronised with forwarding speed. Negative safety hydraulic brake to stop the PTO |
| PTO clutch | Multidisc in oil bath with electro-hydraulic control |
| PTO rotation speed (rpm) | 540 |
| HYDRAULIC SYSTEM | Dual circuit with independent pumps |
| Hydraulic pump flow rate of the power steering and electro-hydraulic controls (l/min) | 15.3 |
| Hydraulic pump flow rate of the lift and control valves (l/min) | 25.6 |
| Maximum hydraulic pressure (bar) | 180 |
| REAR CONTROL VALVES | Mechanically controlled |
| Standard | With rear up/down lift: 1 double-acting with free flow oil return predisposition (total 2 hydraulic outlets) With draft-controlled rear lift: 2 double acting (total 4 hydraulic outlets) |
| Optional | With rear up/down lift: up to 7 hydraulic outlets in total and free flow oil return With draft-controlled rear lift: up to 4 hydraulic outlets in total |
| REAR LIFT | By two external cylinders. Standard: up/down lift - Optional: position and draft-controlled |
| 3-point implement hitch | Standard: normal couplings cat. 1 Optional: quick-couplings cat. 1, L-shaped, arms adjustable in length and hooks adjustable in width |
| Third point tie rod | With manual adjustment |
| Ball joint lifting capacity (kg) | 1200 |
| DRIVING POSITION | Monodirectional or Reversible with rotating platform and twin pedal assembly |
| Steering wheel | Fixed |
| Seat | Comfort seat with adjustable suspension according to the operator's weight |
| SERVICE BRAKES | Multidisc in oil bath with mechanical control, acting on the rear wheels |
| Parking brake | Acting on service brakes |
| STEERING | Hydrostatic steering acting on the central joint. Flow deviator for steering unit in the reversible version |
| SAFETY | Front homologated roll-bar |
| DASHBOARD | With chrono-tacho-gyrometer, water thermometer, control warning lights and acoustic alarm. Reading of rpm, forward speed and rotation speed of pto |
| ELECTRIC SYSTEM | Battery 100 Ah - Alternator 80 A |
| TYRES | 8.25-16 * 210/95R16 (7.50-16) * 250/80-18 * 280/70R18 * 280/70R18 Garden * 320/65R18 * 260/70R20 * 31x15.50-15 XTC * 31x15.50-15 STG * 33x15.50-15 XTC |
| TOW HOOKS | Standard: front and rear CUNA cat. B adjustable in height - Optional: rear tow hook EC approved |
| RUNNING ORDER WEIGHT | With roll-bar: 1510 kg |
| ADDITIONAL OPTIONS | Beacon lamp, front weights 100 kg total and wheel weights 45 kg each |

VALIANT 600 RS

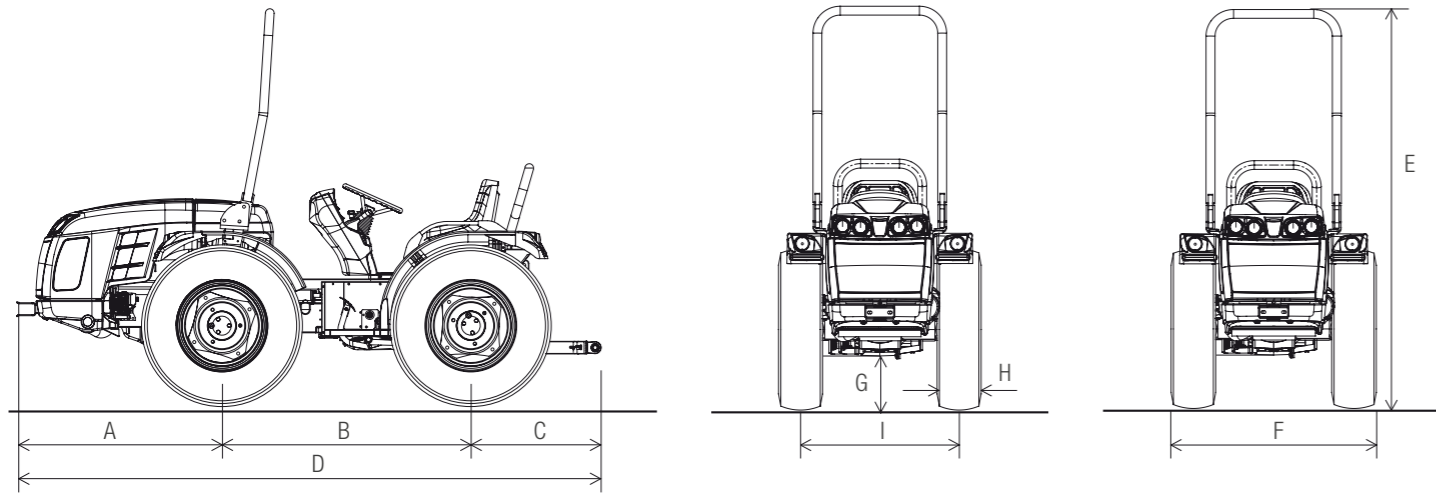

| A | B | C | D | E min / max | F min / max | G min / max |
|------|------|-----|------|----------------|----------------|----------------|
| 1157 | 1340 | 779 | 3276 | 2145 / 2220 | 1207 / 1643 | 220 / 270 |

Dimensions in mm

| | 8.25-16 WITH ADJUSTABLE RIM | 210/95 R16 (7.50-16) WITH ADJUSTABLE RIM | 250/80-18 WITH ADJUSTABLE RIM | 280/70 R18 WITH ADJUSTABLE RIM | 280/70R18 Garden WITH ADJUSTABLE RIM |
|----------|--------------------------------|---|----------------------------------|-----------------------------------|--|
| H | 212 | 208 | 240 | 282 | 282 |
| I | 999 / 1305 | 999 / 1305 | 996 / 1312 | 984 / 1324 | 984 / 1324 |
| F | 1211 / 1517 | 1207 / 1513 | 1236 / 1552 | 1266 / 1606 | 1266 / 1606 |

| | 320/65 R18 WITH ADJUSTABLE RIM | 260/70 R20 WITH ADJUSTABLE RIM | 31x15.50-15 XTC WITH FIXED RIM | 31x15.50-15 STG WITH FIXED RIM |
|----------|-----------------------------------|-----------------------------------|-----------------------------------|-----------------------------------|
| H | 319 | 258 | 368 | 394 |
| I | 1074 / 1324 | 987 / 1325 | 1100 / 1208 | 1100 / 1208 |
| F | 1393 / 1643 | 1245 / 1583 | 1468 / 1576 | 1494 / 1602 |

Dimensions in mm - min / max
H = Tyre width - I = Wheel track - F = Tractor width

| VALIANT 600 RS | |
|---|---|
| ENGINE | 4-cycle diesel engine with direct injection |
| Manufacturer | Kohler |
| Model | KDi 2504M |
| Number of cylinders | 4 |
| Displacement cm ³ | 2482 |
| Suction | Naturally aspirated |
| Power KW/HP | 36 / 49 |
| Nominal speed (rpm) | 2600 |
| Maximum tractor torque (Nm/rpm) | 170 / 1500 |
| Cooling | Water |
| Tank capacity (l.) | 45 |
| CHASSIS | Swinging integral chassis (±15°) OS-FRAME with steering wheels |
| DRIVE | Permanent four-wheel drive |
| TRANSMISSION | 24-speed synchronised gearbox: 12 FWD and 12 REV with synchronised reverser |
| Transmission clutch | Multidisc in oil bath |
| DIFFERENTIAL | Front and rear with simultaneous locking and electro-hydraulic control |
| AXLES | Front and rear with planetary reduction units |
| REAR PTO | Independent from the gearbox and synchronised with forwarding speed. Negative safety hydraulic brake to stop the PTO |
| PTO clutch | Multidisc in oil bath with electro-hydraulic control |
| PTO rotation speed (rpm) | 540 |
| HYDRAULIC SYSTEM | Dual circuit with independent pumps |
| Hydraulic pump flow rate of the power steering and electro-hydraulic controls (l/min) | 15.3 |
| Hydraulic pump flow rate of the lift and control valves (l/min) | 25.6 |
| Maximum hydraulic pressure (bar) | 180 |
| REAR CONTROL VALVES | Mechanically controlled |
| Standard | With rear up/down lift: 1 double-acting with free flow oil return predisposition (total 2 hydraulic outlets) With draft-controlled rear lift: 2 double acting (total 4 hydraulic outlets) |
| Optional | With rear up/down lift: up to 6 hydraulic outlets in total With draft-controlled rear lift: up to 4 hydraulic outlets in total |
| REAR LIFT | By two external cylinders. Standard: up/down lift - Optional: position and draft-controlled |
| 3-point implement hitch | Standard: normal couplings cat. 1 - Optional: quick-couplings cat. 1 (arms not adjustable in length) or quick-couplings cat. 1 and 2, L-shaped, arms adjustable in length and hooks adjustable in width |
| Third point tie rod | With manual adjustment |
| Ball joint lifting capacity (kg) | 1200 |
| DRIVING POSITION | Monodirectional or Reversible with rotating platform and twin pedal assembly |
| Steering wheel | Fixed |
| Seat | Comfort seat with adjustable suspension according to the operator's weight |
| SERVICE BRAKES | Multidisc in oil bath with mechanical control, acting on the rear wheels. Independent manoeuvring brakes acting on the rear wheels |
| Parking brake | Acting on service brakes |
| STEERING | Hydrostatic steering acting on the front wheels. Flow deviator for steering unit in the reversible version |
| SAFETY | Front homologated roll-bar |
| DASHBOARD | With chrono-tacho-gyrometer, water thermometer, control warning lights and acoustic alarm. Reading of rpm, forward speed and rotation speed of pto |
| ELECTRIC SYSTEM | Battery 100 Ah - Alternator 80 A |
| TYRES | 8.25-16 * 210/95R16 (7.50-16) * 250/80-18 * 280/70R18 * 280/70R18 Garden * 320/65R18 * 260/70R20 * 31x15.50-15 XTC * 31x15.50-15 STG |
| TOW HOOKS | Standard: front and rear CUNA cat. B adjustable in height - Optional: rear tow hook EC approved |
| RUNNING ORDER WEIGHT | With roll-bar: 1520 kg |
| ADDITIONAL OPTIONS | HDR hydraulic suspension with accumulator including 4 hydraulic outlets (only for reversible version), beacon lamp, front weights 100 kg total and wheel weights 45 kg each |

THE SERVICES



SPARE PARTS

A complete range of original spare parts, guaranteed directly by the manufacturer.



ASSISTANCE

A team of specialists, well prepared and available to assure an efficient and resolving service.



WARRANTY

A precise certainty for the customer's satisfaction: 2-year warranty included in the price.



LUBRICANTS

BCS recommends to use the original PowerLube lubricants.



MADE IN ITALY

BCS S.p.A.

Viale Mazzini, 161
20081 Abbiategrasso (Milano)
Tel. +39 02 94821
info@bcs-ferrari.it

www.bcsagri.com

